



承认书

SPECIFICATION FOR APPROVAL

客户名称:

CUSTOMER _____

产品名称:

红外接收头

PARTANME _____

规格料号:

HRM-5042AM36-TRZ

PART NO _____

客户签章			鸿利泰签章		
DESIGNER	CHECKER	APPROVER	DESIGNER	CHECKER	APPROVER
			田振挺	袁军	马祥利

鸿利泰光电科技有限公司

HONGLITAI PHOTOELECTRICITY CO.,LTD
深圳市宝安沙井街道芙蓉工业区芙蓉 6 路 122 号
Tel:0755-29504006
Fax: 0755-29504016
<http://www.hlt-opto.com>

INFRARED RECEIVER MODULE

● Description

The HRM-5042AM36-TRZ is miniaturized infrared receivers for remote control and other applications requiring improved ambient light rejection.

The separate PIN diode and preamplifier IC are assembled on a single lead frame.

The epoxy package contains a special IR filter.

This module has excellent performance even in disturbed ambient light applications and provides protection against uncontrolled output pulses.



● Features

- Supply voltage range: 2.7V ~ 5.5 V
- TTL and CMOS compatibility
- No external components except PIN diode
- Available for carrier frequencies between 32.7kHz to 40kHz,(Adjusted by zener-diode fusing, 32.7kHz,36.7kHz,37.9kHz,40kHz)
- Internal filter for PCM frequency
- Enhanced immunity against all kinds of disturbance light and power noise (Built-in Filter & AGC Circuit)
- No occurrence of disturbance pulses at output pin within nominal conditions.
- Open collector output & Output active low (Built-in Pull-up resistor 50 k Ω)
- The output pulse width is very stable (Optimized for a narrow margin of the decoding)

● Applications:

1. Optical switch
2. Light detecting protion of remote contol
 - AV instruments such as Audio,TV,VCR,CD,MD,DVD,etc.
 - Home appliances such as Air-conditioner,Fan,etc.
 - CATV set top boxes
 - Multi-media Equipment

● Cautions

- store and use where there is no force causing transformation or change in quality
- store and use where there is no extreme humidity
- in order to prevent damage from static electricity make sure that the human body and the Soldering iron are connected to ground before using
- the ripple noise from power supply lines may shorten detecting distance of IT receiver module Thus in order to ensure more reliable operating please add RC filter (R=100 C=47) between Vcc and GND
- when a disturbance signal is applied to the series it can still receive the data signal However the sensitivity is reduced to the level that no unexpected pulses will occur Some examples of such disturbance signals which can be suppressed pulses by the series
 - A DC light(ex from tungsten lamp or sunlight)
 - B Continuous signal at center frequency or any other frequency
 - C Signals from fluorescent lamps with electronic ballast with high or low mosulation

● **Absolute Maximum Ratings**($T_a=25^{\circ}\text{C}$)

Parameter	Symbol	Ratings	Unit	Notice
Supply Voltage	V_{cc}	0 - 7.0	V	—
Supply Current	I_{cc}	0~2.5	mA	
Operating Temperature	T_{opr}	-20~+80	$^{\circ}\text{C}$	—
Storage Temperature	T_{stg}	-30~+85	$^{\circ}\text{C}$	—
Soldering Temperature	T_{sol}	260 t<5sec	$^{\circ}\text{C}$	
Reflow soldering temperature	T_{sol}	260 t<10sec	$^{\circ}\text{C}$	

● **Electrical And Optical Characteristics**($T_a=25^{\circ}\text{C}$)

Parameter	Symbol	Ratings			Unit	Condition	
		Min.	Typ.	Max.			
Supply Voltage	V_s	2.7	5.0	5.5	V		
Supply Current	I_{cc}	0.37	0.57	0.77	mA	$V_{cc}=5V$	No signal input
		0.34	0.53	0.73		$V_{cc}=3V$	
Reception Distance	L_0	20	—	—	m	At the ray axis*1	
	L_{45}	10	—	—			
B.P.F Center Frequency	f_o	—	36	—	KHz		
BPF Bandwidth	fbw	2.5	4.5	6.5	KHz	$V_{cc}=5V$ $f_{in}=37.9\text{kHz}$ -3DbBand width $V_{in}=30\mu V_{pp}$	
		2.5	4.5	6.5	KHz	$V_{cc}=3V$ $f_{in}=37.9\text{kHz}$ -3DbBand width $V_{in}=30\mu V_{pp}$	
Peak Wavelength	λ_p	—	940	—	nm		
Half Angle	θ	—	45	—	deg	At the ray axis *1	
High Level Pulse Width	T_H	450	600	750	μS	At the ray axis *2	
Low Level Pulse Width	T_L	450	600	750	μS		
High Level Output Voltage	V_H	4.7	5.0	—	V	$V_{cc}=5V$	
		2.7	3.0	—		$V_{cc}=3V$	
Low Level Output Voltage	V_L	0	0.2	0.4	V		

*1: The ray receiving surface at a vertex and relation to the ray axis in the range of $\theta=0^{\circ}$ and $\theta=45^{\circ}$

*2: A range from 30cm to the arrival distance. Average value of 50 pulses

● Test Method

A. Standard Transmitter

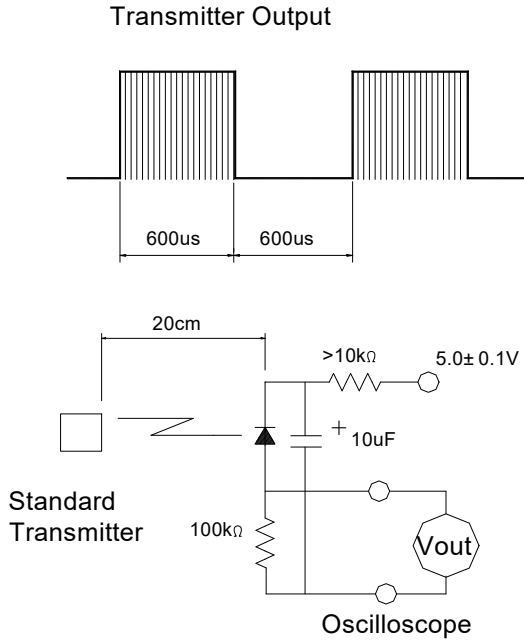

B. Detection Length Test

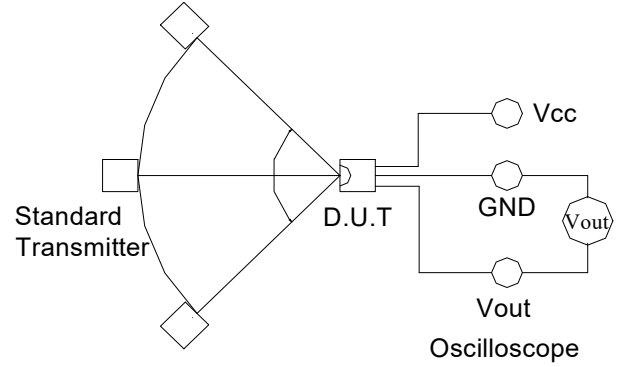

C. Pulse Width Test

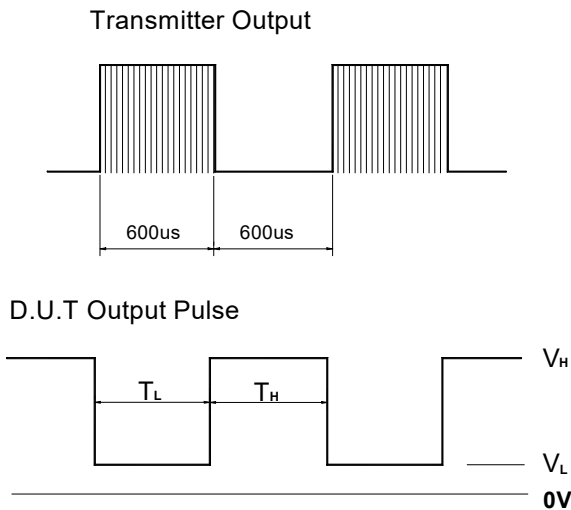

● Application Circuit

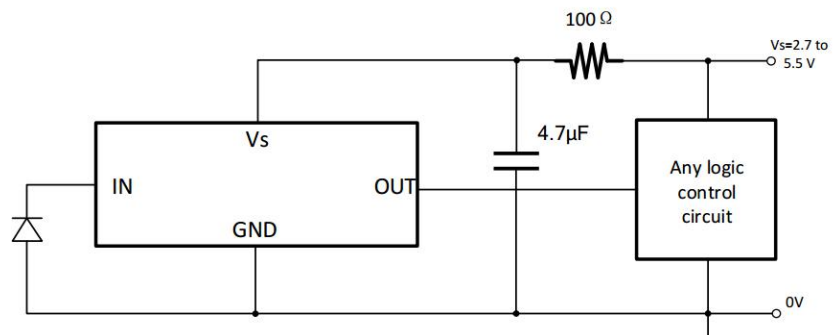

● Package Dimensions:

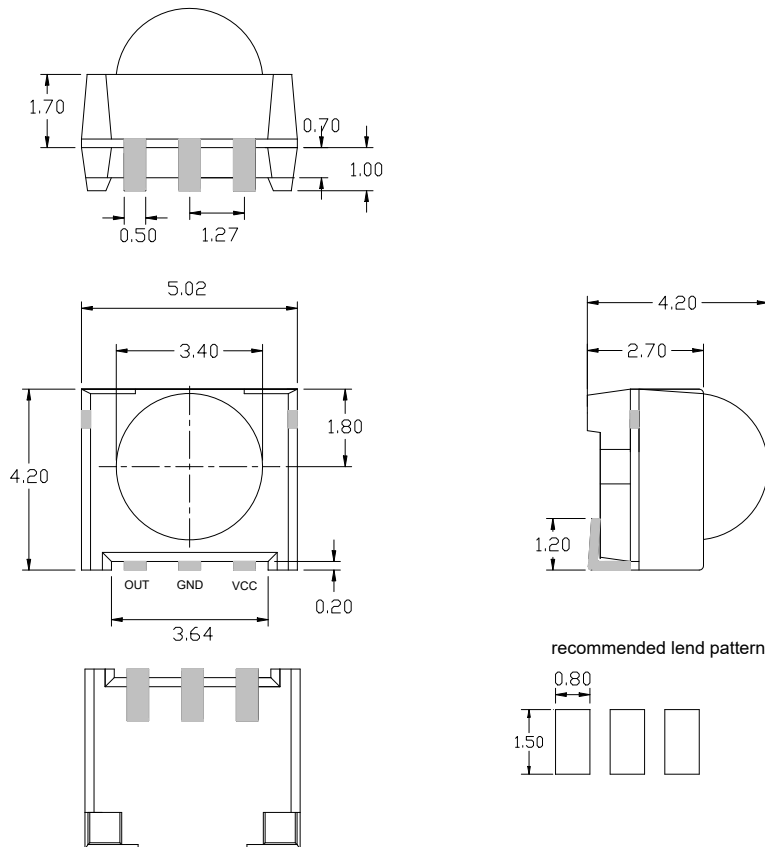

NOTES:

1. All dimensions are in millimeters (inches).
2. Tolerance is $\pm 0.30\text{mm}$ (0.012") unless otherwise specified.
3. Specifications are subject to change without notice.

● Function block diagram

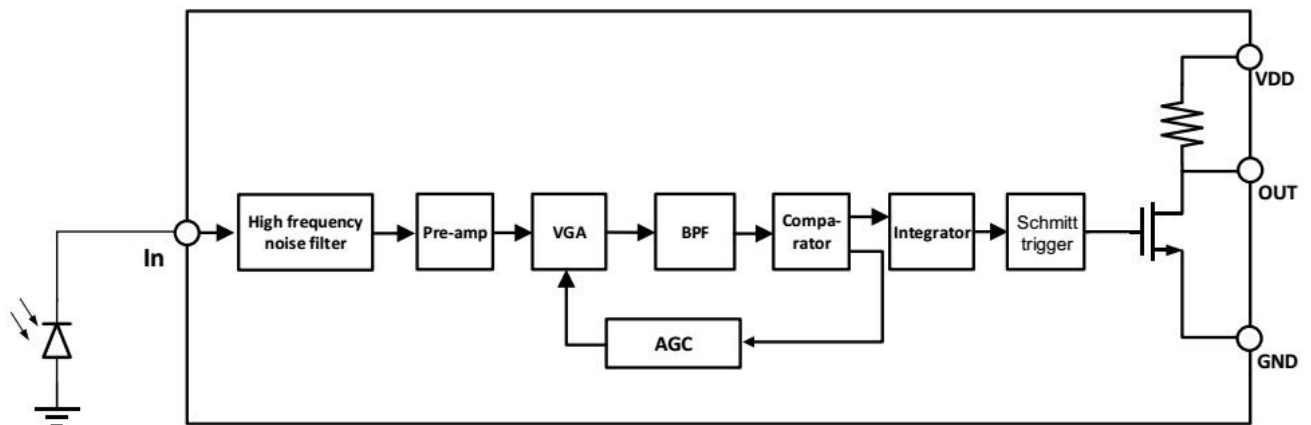

● Electrical And Optical Curves(Ta=25°C)

Fig.1 Relative Spectral Sensitivity vs. Wavelength

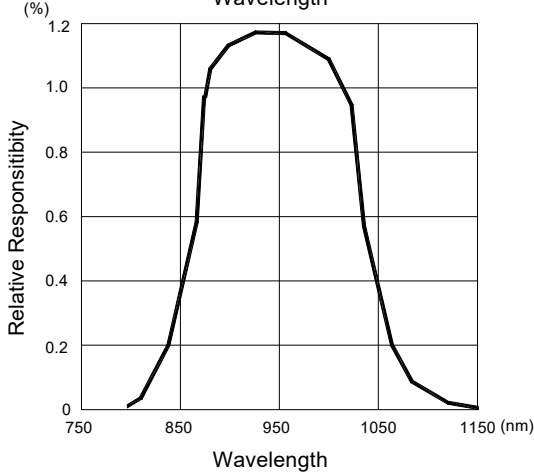

Fig.2 Relative Transmission Distance Vs. Direction

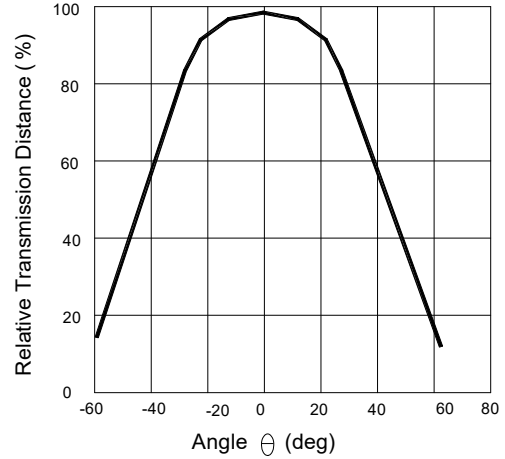

Fig.3 Frequency Dependence of Responsivity

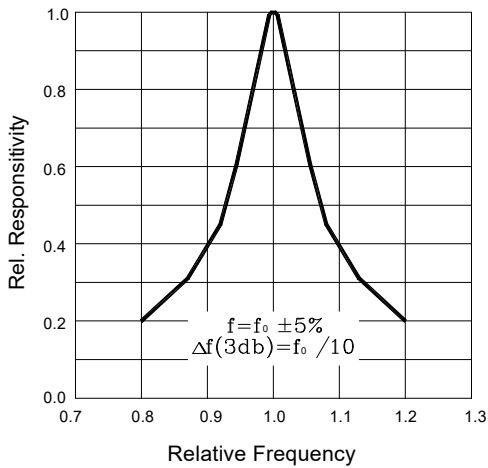

Fig.4 Supply Current vs. Ambient Temperature

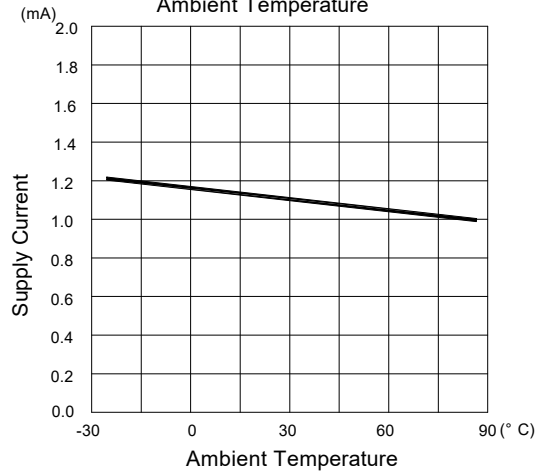
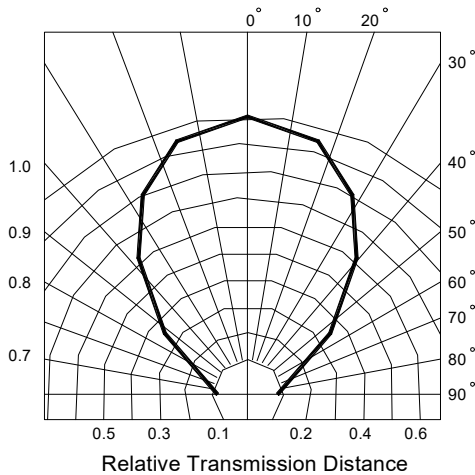

Fig.5 Relative Transmission Distance vs. Direction



ESD Test Results

Parameter	Specification	Results
Machine Model	Min ±200V	> ±400V
Human Body Model	Min ±2000V	> ±4000V
Charged Device Model	Min ±400V	> ±600V

● Suitable Data format

Item	Symbol	Time
Minimum burst length	tBurst	150us
Minimum gap time after each burst	tGap	150us
Minimum pause time in the data stream	t _{pause_min}	>1ms

t_{Pause_min} Could be changed by different data word format. Therefore, for new application on sets please refer to "Required data pause time(t_{Pause})" on above.

● Reliability Test Items

Parameter	Test conditions	Remark
High Temperature	Ta=+85, VCC=5.0V t=240h	※1, ※2
Low Temperature	Ta=-30, VCC=5.0V t=240h	※1, ※2
High Temp./ High Humidity	Ta=+85℃ 85%RH, VCC=5.0V t=240h	※1, ※2
Heat Cycle	Ta=-20℃(0.5h) to +85℃(0.5h) 20 cycle	※2, ※3
Fall Test	Height=75cm, 3 times	※4

※ 1. Supply voltage of load test is 5V.

※ 2. Electro-optical characteristics shall be satisfied after leaving 2 hours in the normal condition.

※ 3. Heat cycle test shall repeat above condition 20 times under no load.

※ 4. The test devices shall be dropped three time on the hard wooden board from a height of 75cm.

● Material Configuration

Parameter	Configuration	Remark
IC	Silicon(99%)	
Photo diode	Silicon(99%)	
Epoxy resin	Resin(55.5%), Hardener(45.5%)	
Silver epoxy	Silver(80%), Resin(10%), Hardener(10%)	
Bond wire	Gold(99.99%)	

● Lead(Pb)-Free Reflow Solder Profile

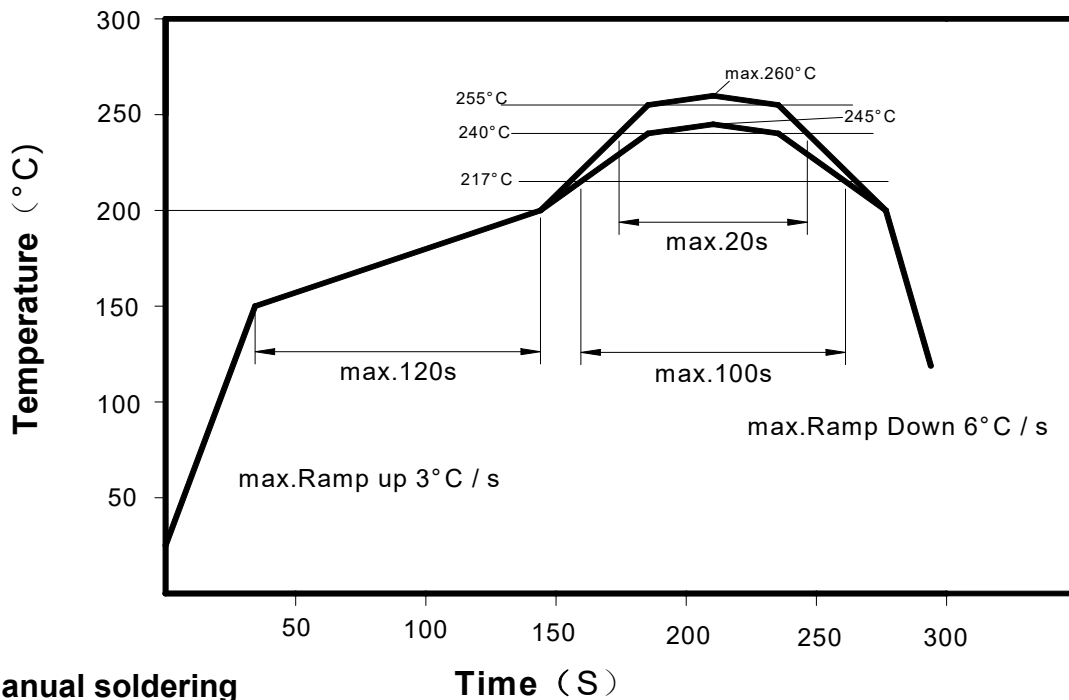

● Manual soldering

Time (S)

Use a soldering iron of 25W or less. Adjust the temperature of the soldering iron below 260°C.

● Taping and reel dimensions in millimeters

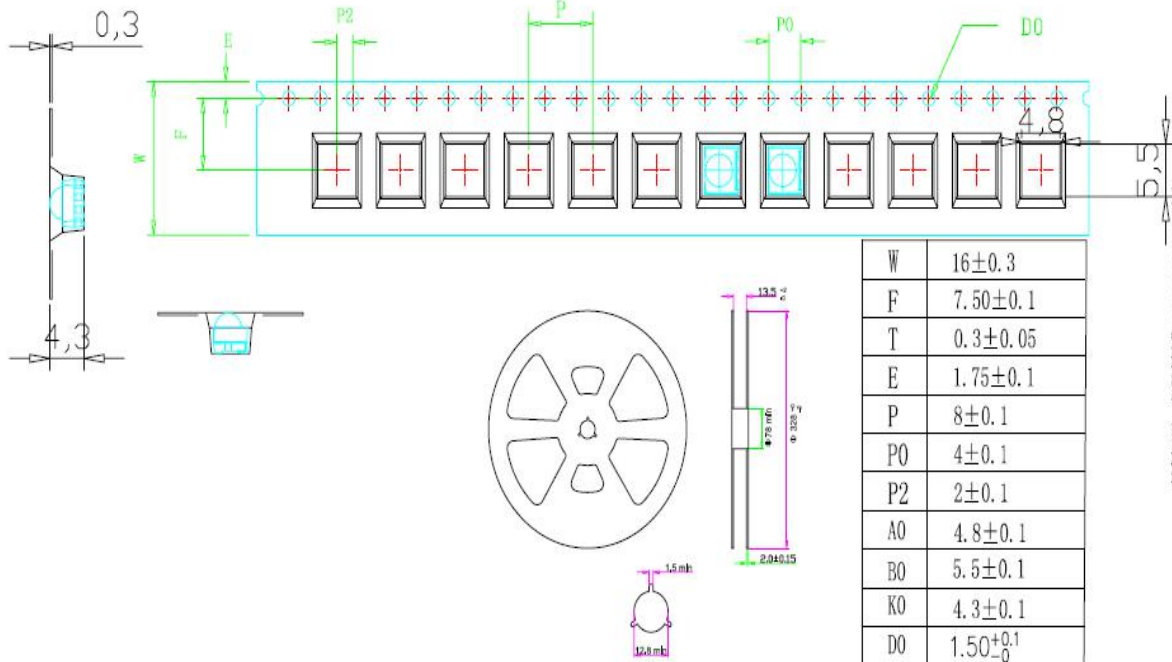

● Packaging Bag Dimensions

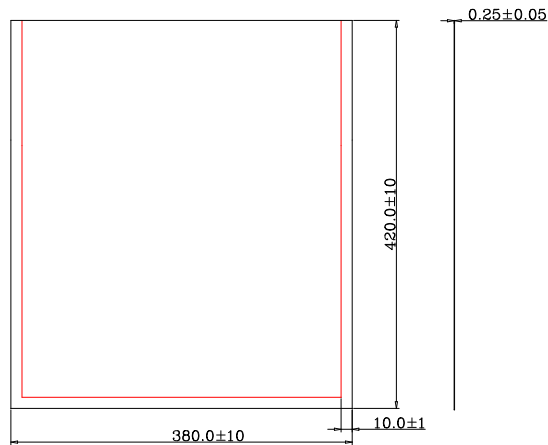

● Packaging Box Dimensions

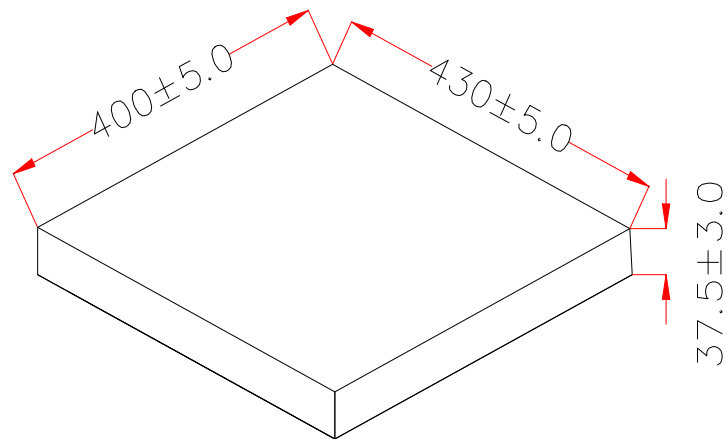

● Packaging outer Box Dimensions

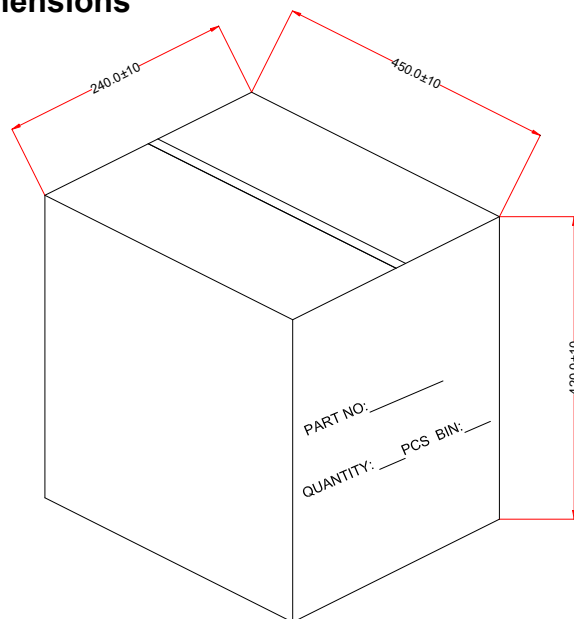

NOTES:

1. 2500 PCS per reel, 2 reels per box, 6 box per Carton.
2. All dimensions are in millimeters (inches).
3. Tolerance is ± 0.30 mm (0.012") unless otherwise specified.
4. Specifications are subject to change without notice.

● **acceptable code list**

data format	code acceptable
NEC	O
RC5_Philips	O
RC6_Philips	O
Toshiba	O
Sony 12 Bit	O
Sony 15 Bit	O
Sony 20 Bit	O
XMP/RCMM	O
Continuous code	O

● **Use matters needing attention**

- store and use where there is no force causing transformation or change in quality
- store and use where there is no extreme humidity
- in order to prevent damage from static electricity make sure that the human body and the Soldering iron are connected to ground before using
- Please from the bottom of the resin for welding for more than 2 mm
- Dip soldering: please below 260 degrees, 5 seconds to complete welding
- Soldering iron: please below 350 degrees, 3 seconds to complete welding
- Please avoid correct position after welding
- When welding in the lead frame please don't put pressure on the heated condition
- When the circuit board is installed, the mounting hole distance is consistent With the lead frame